

Guidelines:

- Carries 2 bikes, up to 80lbs (36kg) each (160lbs (72kg) total)
- Tire width 19mm road bike tires – 4.5" mountain bike tires
- Wheel Diameter: 20" - 29"
- Wheelbase: 34" - 55" (889mm - 1397mm)
- Use for single rider bikes and e-bikes only, no mopeds, scooters, tandems, recumbents, multi-rider bikes, motorcycles or non traditional bikes
- Not compatible with bikes equipped with front cargo racks. Front cargo racks must be removed prior to use
- Not compatible with any third party hitch extensions, swing out adapters, spacers, or any other third party components between the rack and the hitch
- Visit www.rockymounts.com/gigawatt for RV ratings and limitations

Parts Included:

- | | | | |
|--------------------|----------------------|--------------------------|----------------------------|
| A: Base (1x) | G: Chain Lock (1x) | M: Hitch Pin (1x) | S: M14 Bolt (1x) * |
| B: Inner Tray (1x) | H: M8 Tray Bolt (8x) | N: M12 Flat Washer (1x) | T: M14 Washer (2x) * |
| C: Outer Tray (1x) | I: Nylon Plate (4x) | O: M12 Split Washer (1x) | U: M14 Nut (1x) * |
| D: Wheel Hoop (2x) | J: M6 Hoop Bolt (4x) | P: 5mm Allen Wrench (1x) | |
| E: Hook Strap (2x) | K: Key (2x) | Q: 4mm Allen Wrench (1x) | * For RV applications only |
| F: Ramp (1x) | L: Lock Pod (2x) | R: 19mm Wrench (1x) | |

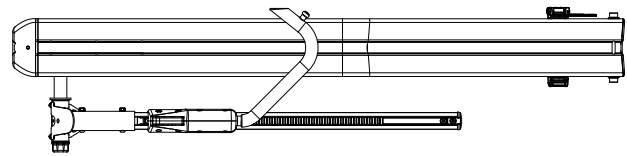

B (1x)

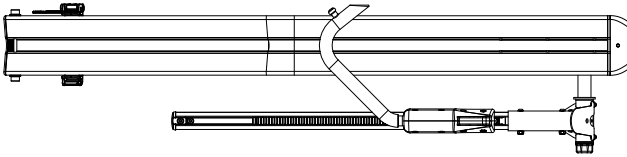

C (1x)



D (2x)

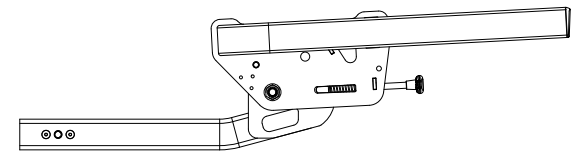

A (1x)

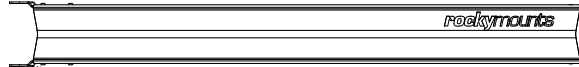

F (1x)



G (1x)



E (2x)

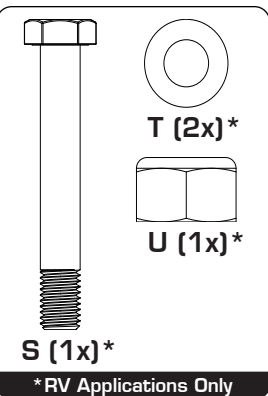

S (1x) *

T (2x) *

U (1x) *

* RV Applications Only

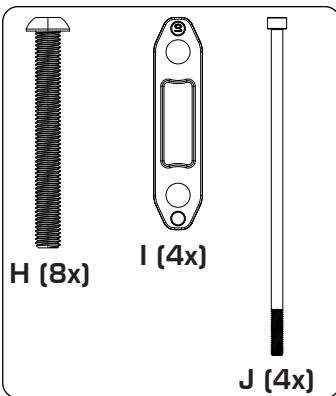

H (8x)

I (4x)

J (4x)

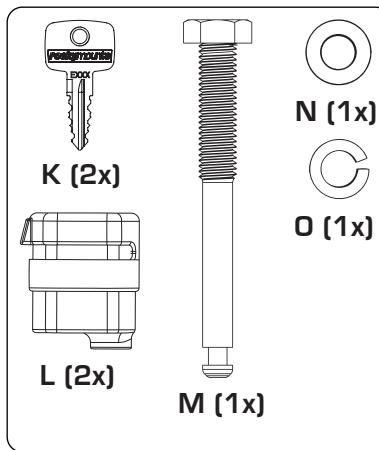

K (2x)

N (1x)

O (1x)

L (2x)

M (1x)

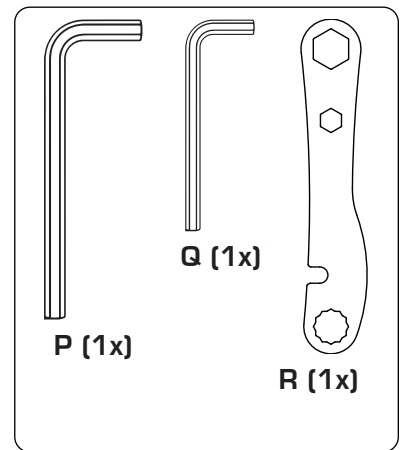

P (1x)

Q (1x)

R (1x)

Assembly Instructions:

1 Install Base

Insert hitch tube into vehicle hitch receiver and align holes. Install the hitch pin with a M12 split washer and M12 flat washer and tighten using 19mm wrench. Lock hitch pin with lock pod.

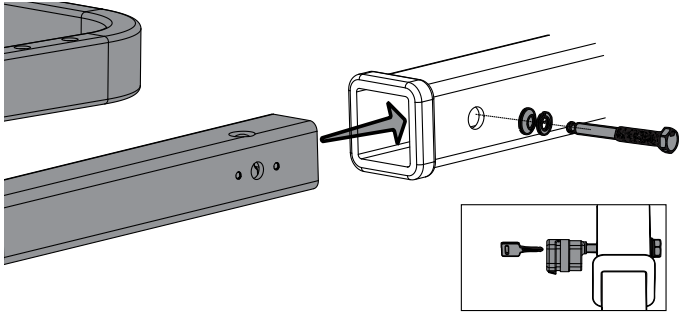

2 Install Inner Tray

Place inner wheel tray on base with load arm facing out. Align plastic posts on underside of tray with mounting holes on base.

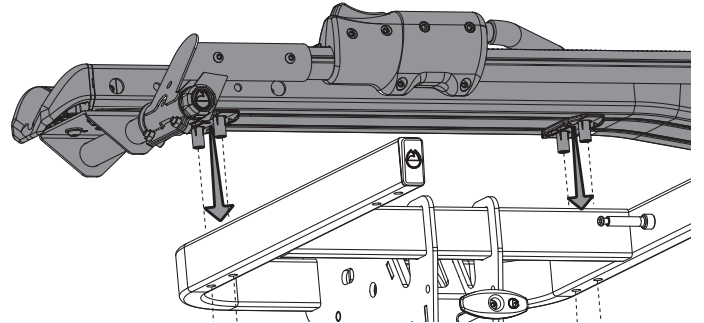

3 Secure Inner Tray

From the underside, loosely install four M8 bolts and nylon plate into the Wheel Tray. When all 4 bolts are started, tighten securely with 5mm allen wrench.

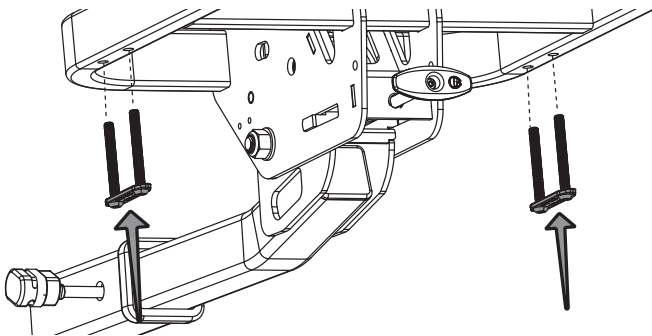

4 Install Wheel Hoop

1: Spread wheel hoop slightly and place onto mating holes on wheel tray. Insert M6 bolts through wheel tray and secure with 5mm allen wrench.
2: Next tighten the middle bolts on each side.

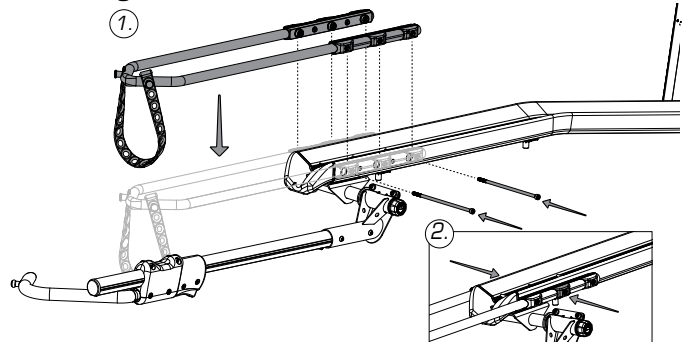

5 Install Outer Tray

Repeat steps 2-4 to install the outer wheel tray and wheel hoop. Once fully assembled, confirm the wheel trays have been installed correctly by checking the "Rockymounts" logo.

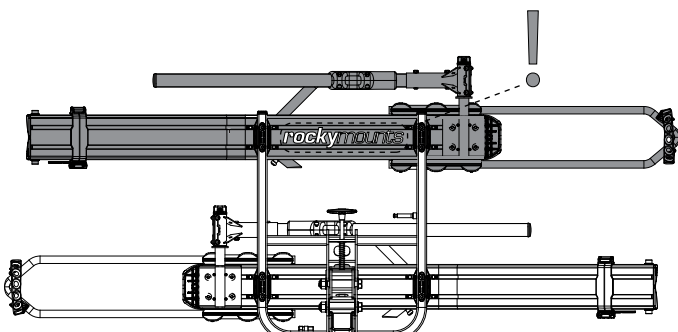

For RV Installs Only:

1 Install Pivot Bolt

If installing rack onto an RV the base pivot must be secured. Insert M14 bolt with washer into pivot block. Install nut and washer and secure using 22mm wrench and adjustable wrench.

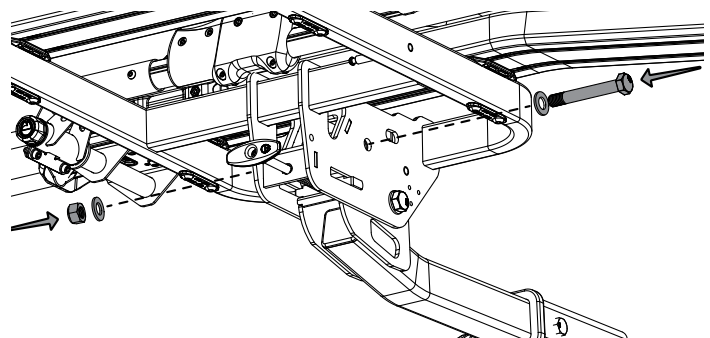

Read all warnings on last page before use.

rockymounts™

Rack Operation:

1 Folding Rack

- Pull 'T' handle to raise or lower the rack into stow, use, and tilt position.
- Rack can be folded into stow position when not in use and tilted down for rear vehicle access.
- Load arms should be stowed flat when rack is not in use.
- 'T' handle should be fully seated before each use.

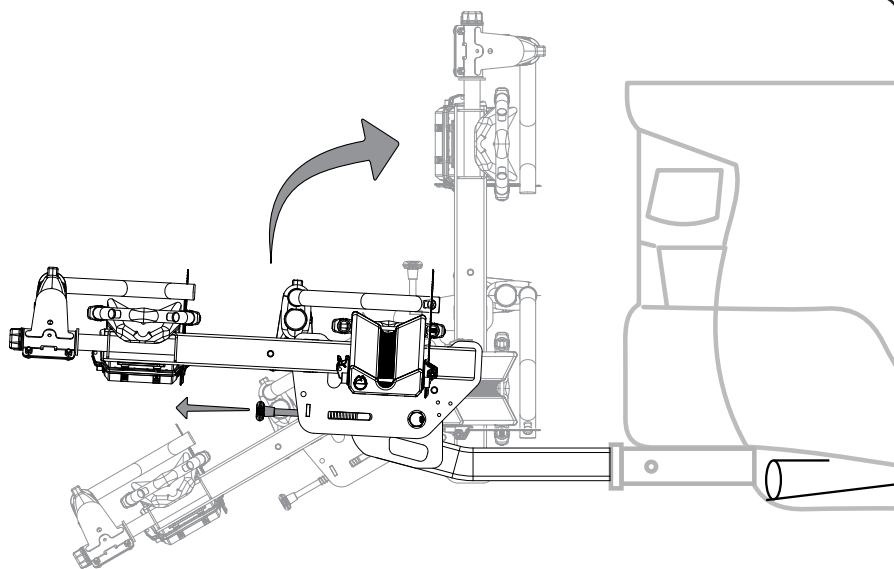

Loading Bikes:

1 Prepare Wheel Tray

- 1: Rotate load arm 180 degrees from stowed position and fully extend the hook.
- 2: Tuck the wheel strap into the wheel tray.

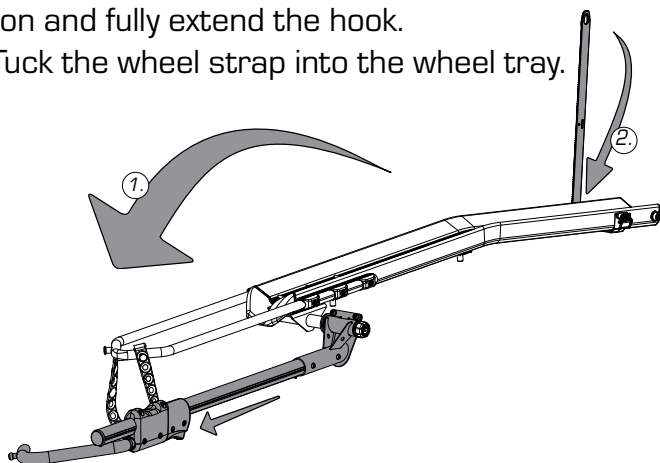

2 Attach Ramp

Hook the ramp onto the two bosses at the end of the wheel tray and rest end of ramp on ground. Ensure ramp is secure and stable.

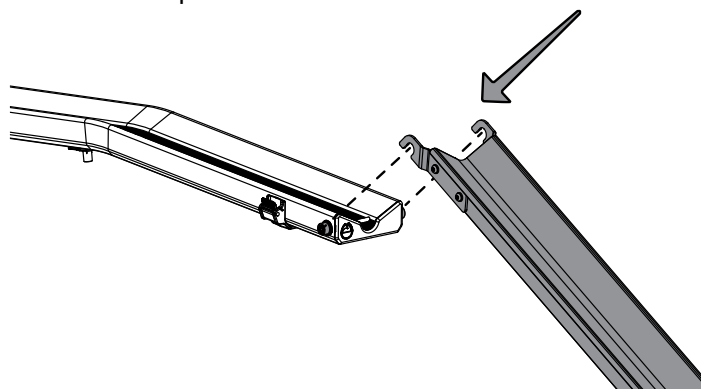

3 Place Bike on Rack

While keeping bicycle vertical, push it up the ramp until the front wheel drops into the Wheel Hoop. Front wheel needs to be aligned in the center of the wheel hoop and fully seated.

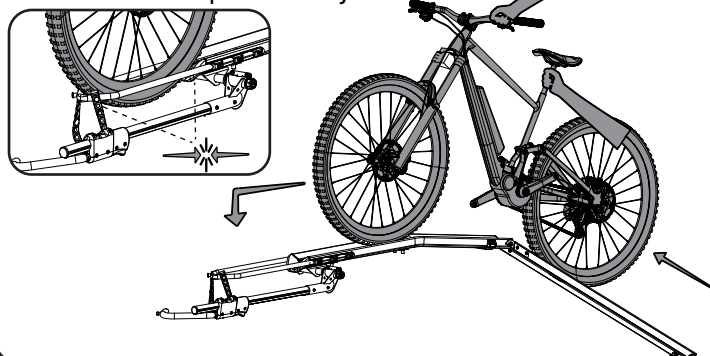

Bikes Without Fenders:

1 Secure Wheel Hook

Rotate Pivot Arm back and push the Hook down with both hands. The Hook must be touching the fork and tire as shown.

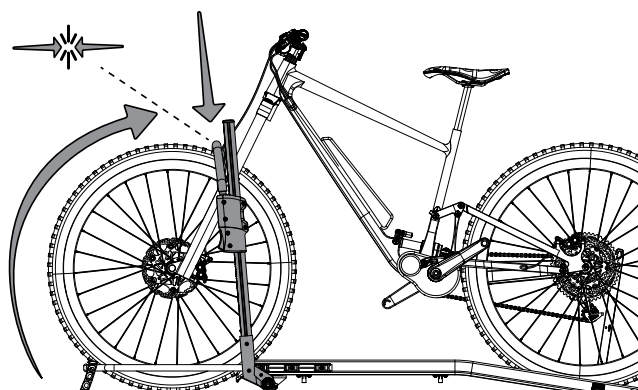

Read all warnings on last page before use.

rockymounts™

Bikes With Fenders (or To Avoid Frame/Fork Contact):

1 Install Hook Strap

Install the large end of the hook strap by stretching it over the nub on the hook and position on the other side.

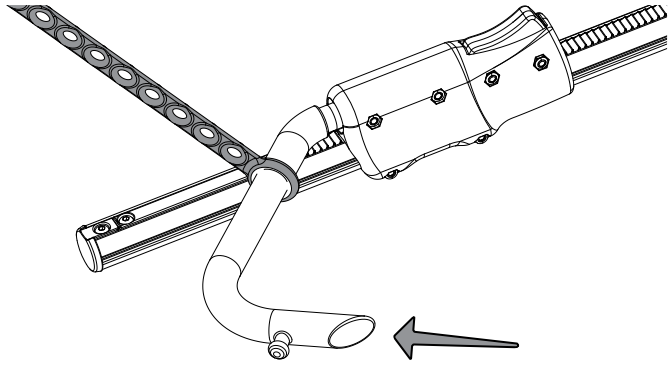

2 Secure Wheel Hook

Rotate load arm over front wheel and tighten hook against the tire. The load arm should be located as close to Fork or Fender, without contacting the Fork or Fender.

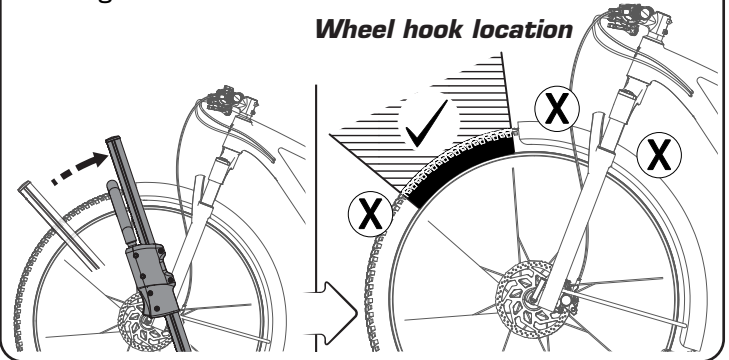

3 Secure Hook Strap

- Feed strap through front wheel.
- Secure strap and hook over attachment point.
- Avoid valve, spokes and sharp edges.

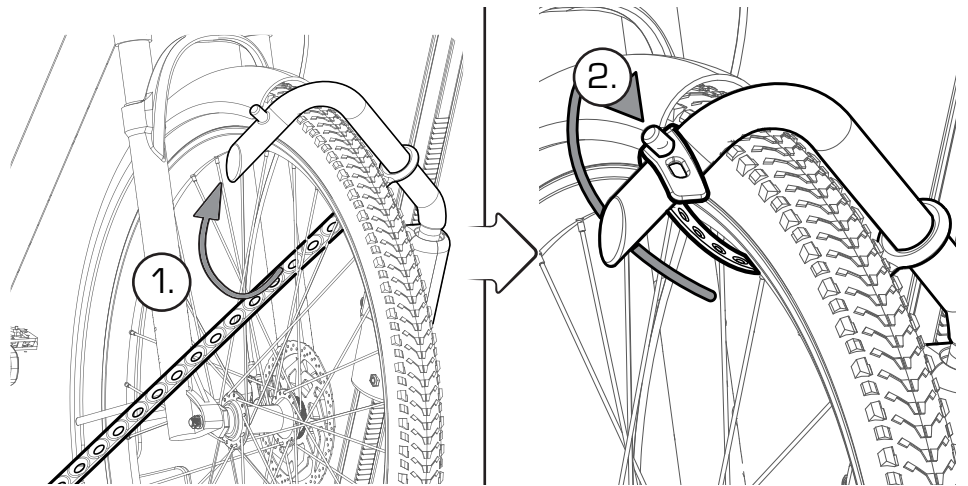

Loading Bikes Continued:

4 Secure Hoop Strap

Remove the end of the Hoop Strap from the Stud, feed through the Front Wheel and onto the Stud on the other side. Reposition wheel if strap lays against a spoke, valve or sharp edge.

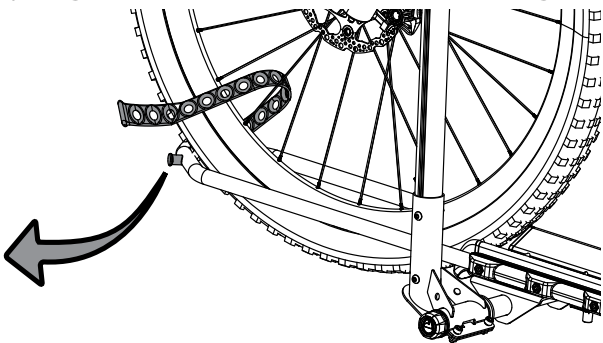

5 Secure Rear Strap

Feed wheel strap through wheel and into Buckle. Pull Tight.

Note: For non fat bike or oversized tires the wheelstrap can be shortened. Remove the bolt securing wheel strap and remove the stop. Position wheel strap in shortened position. Reinstall stop and bolt.

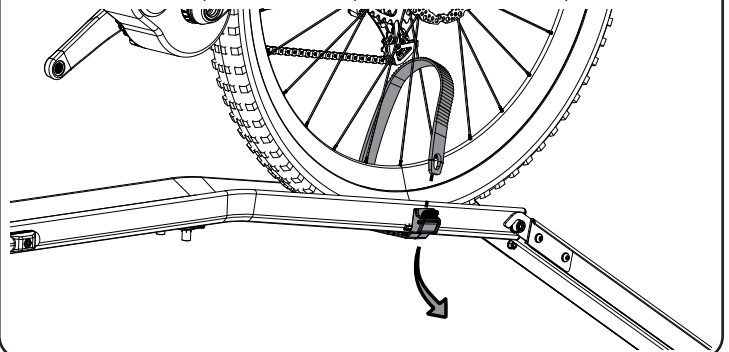

Read all warnings on last page before use.

rockymounts™

Before Travel:**1 Check Rack**

Check that the rack is secure, all fasteners and hitch bolt are tightened and all components are in proper working order. Ensure the loading ramp has been removed.

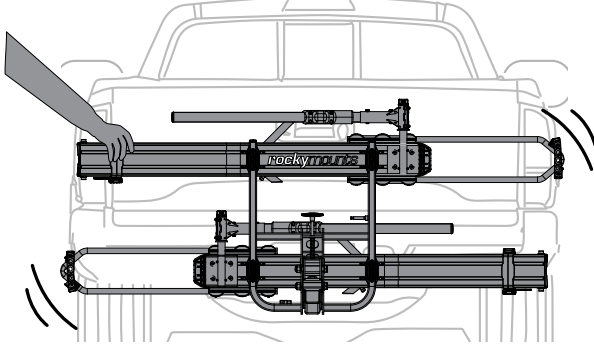
**2 Check Bikes**

Shake bikes and front wheels to check the bikes and wheels are securely installed onto rack. The bikes should not move and the front wheel should not wiggle.

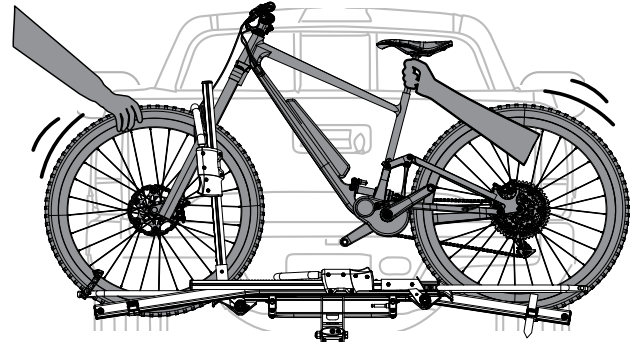
**4 Check Mirrors**

Be sure loaded bikes do not extend past width of side view mirrors

**5 Check Exhaust**

Ensure there is adequate clearance between the exhaust and any plastic parts or bike tires. If the exhaust vents directly rearward we suggest a minimum clearance of 10 inches.

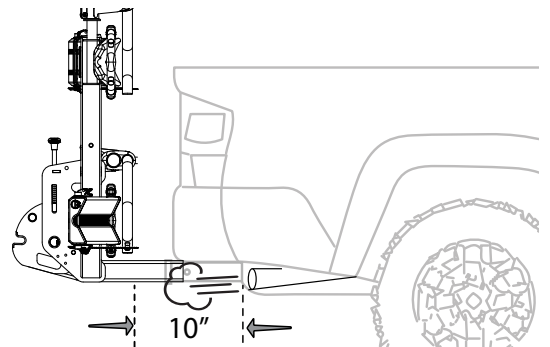
**Locking Bikes:****1 Loop Chain**

Loop chain around first bicycle frame then feed the tail end through the second bicycle frame.

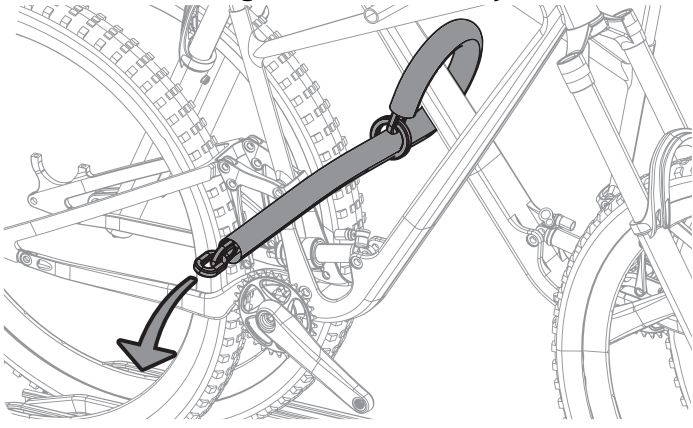
**2 Lock Chain**

Insert the Chain into the lock pin located on the inside of the U shaped frame and lock chain with lock pad.

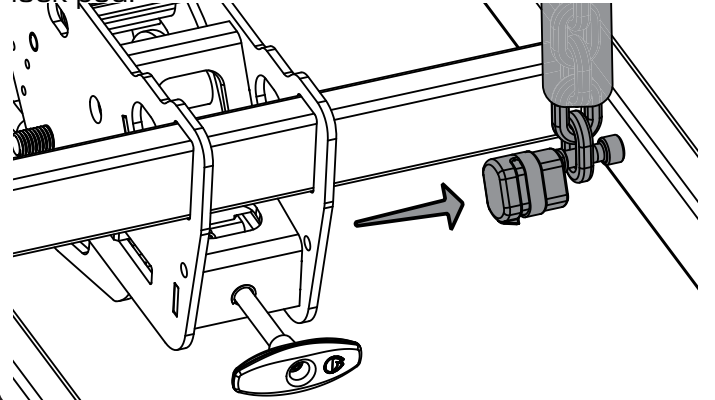

Read all warnings on last page before use.

rockymounts™

Warnings:

- Do not use third party hitch extensions, swing out adapters, spacers, or any other third party components between the rack and the hitch. RockyMounts™ 8" Hitch Extensions are the only approved component.
- Remove baby seats, panniers, U-locks, or items that could detach from the bicycle
- Do not use bicycle covers, bicycle bras, or bicycles equipped with rear aero disc wheel(s)
- Not intended for off road use or with trailers, towed vehicles, 1 ton pickups, or UHV/UTVs. For RV Ratings and limitations visit www.rockymounts.com/gigawatt
- Bikes and rack can partially block license plate and/or taillights. Please check and adjust accordingly
- Check the car exhaust is not pointing at the rack, bike tires, or rims. Some vehicles may require exhaust diversion to avoid damage
- Do not transport bikes with flat or leaking front tires. Front tire must be inflated for secure transport
- Hitch receivers require a minimum of III, IV rating and 2" (50mm) distance from hitch pin hole to end of receiver
- Locks are only deterrents for thieves, RockyMounts™ Inc. Cannot be held liable for stolen bicycles
- Check all fasteners before each use
- Remove bikes and rack before entering car wash, hand washing rack is OK
- Once a year, remove from car to clean and inspect for damage
- Wheel straps are subjected to age, wear and deterioration - It is the responsibility of the Owner/User to evaluate and replace straps when needed.

Check Exhaust Clearance

Ensure there is adequate clearance between the exhaust and wheel trays. If the exhaust vents directly rearward we suggest a minimum of 10 inches between the tail pipe and the wheel cups. An exhaust diverter may also be used to direct the exhaust downward

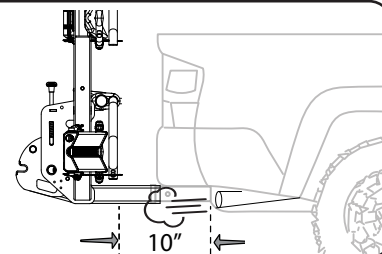

Register Your Rack:

To Register your new RockyMounts™ either scan the QR code located on the product itself and the box, or go to www.rockymounts.com/register to fill out the form.

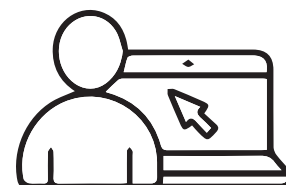

Limited Lifetime Warranty:

At RockyMounts we offer a Limited Lifetime Warranty for products purchased after January 1, 2014 to the original owner. For details of warranty, how to make a claim, and how to register your product; please see www.rockymounts.com/warranty

Technical Support:

Please call use at (303) 402-0190 or email at ride@rockymounts.com for questions regarding use, assembly, and support