

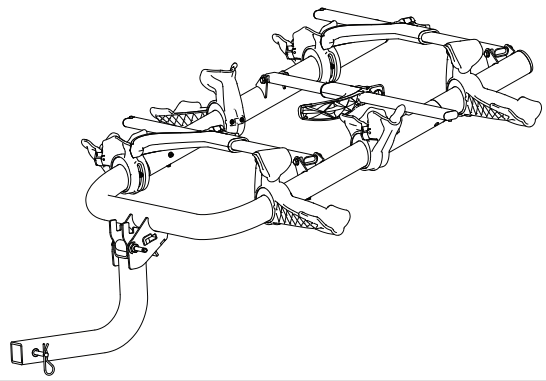

rockymounts
WestSlope 3



Guidelines

Max weight per bicycle: 40lbs (18kg) for 3 bike rack (120lbs (54kg) total).
 Wheel size: Comptatible with 20-29" wheels.
 Tire Size: Fits up to 3.0" tires.
 Compatible with bicycles' wheelbases from 36" to 50"
 Fits 2" hitches with anti wobble bolt
 Remove front fenders, racks, and panniers before use.
 No kick bikes, recumbents, mopeds, scooters, pennyfarthings, fat bikes, or tandems.

Parts Included

- | | | | |
|--------------------------|-------------------------|---------------------|--------------------|
| A: Base | H: Left Outer Frame Arm | O: Pivot Bolt | V: M8 Flat Washer |
| B: Frame | I: Right Frame Arm | P: M6x85 Allen Bolt | W: M8 Nut |
| C: Inner Front Wheel Cup | J: Ratchet Arm | Q: M8x70 Hex Bolt | X: 1/2" Nut |
| D: Outer Front Wheel Cup | K: Hook | R: M4x6 Allen Bolt | Y: 6mm Flat Washer |
| E: Inner Rear Wheel Cup | L: Wheel Strap | S: M6x15 Torx Bolt | X: Cotter Pin |
| F: Outer Rear Wheel Cup | M: Rubber Bumper | T: M12 Flat Washer | |
| G: Left Inner Frame Arm | N: Hitch Bolt | U: M12 Lock Washer | |

Tools Included

- AA: Box Wrench BB: M3 Hex Wrench CC: M4 Hex Wrench DD: M5 Hex Wrench EE: Torx Wrench

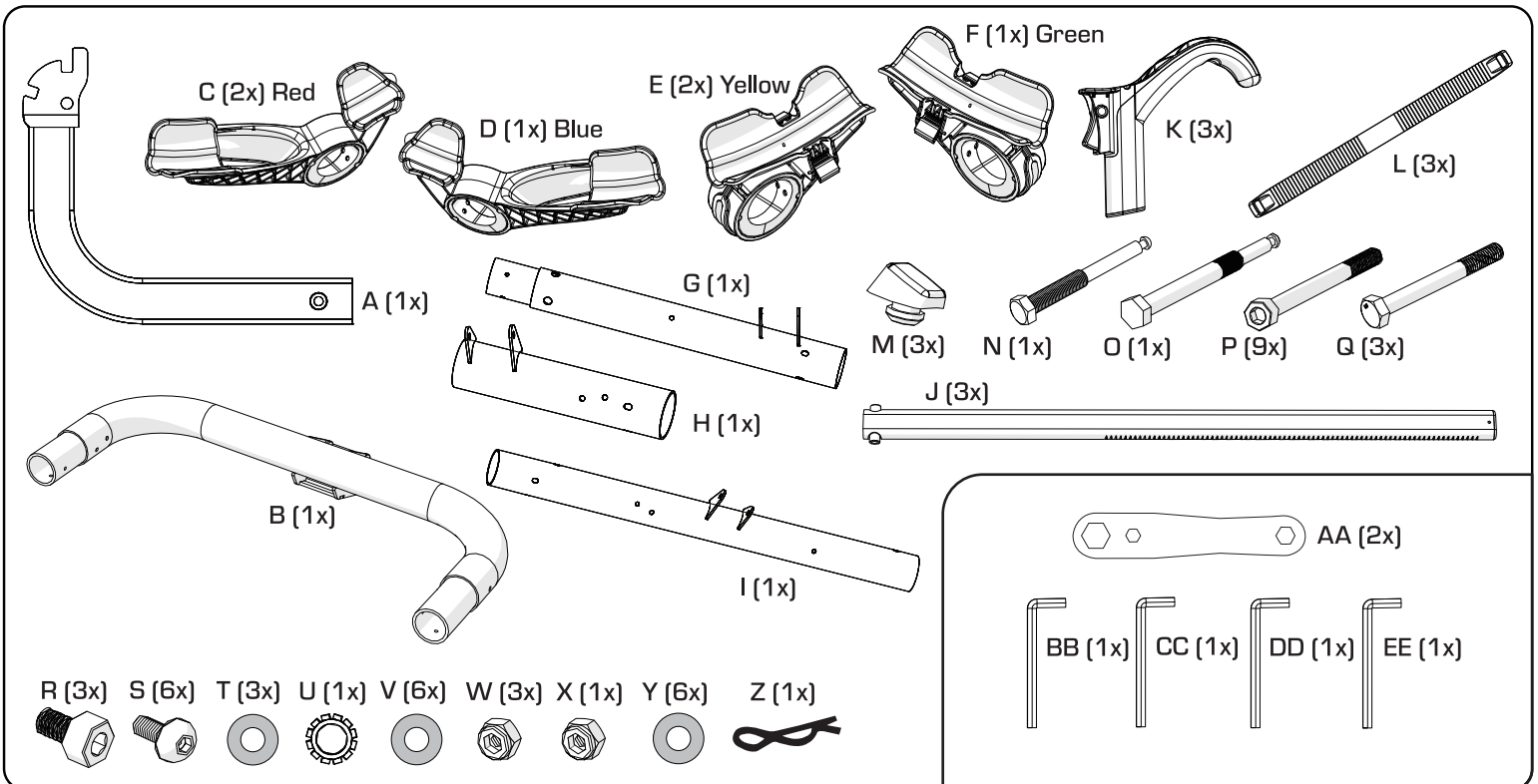

Read all warnings on last page before use. **rockymounts™**

Assembly Instructions

1 Install Hitch Bolt

Insert base (A) into vehicle hitch receiver. Install hitch bolt (N) with M12 flat washer (T) and M12 lock washer (U) using box wrench (AA). Install cotter pin (Z)

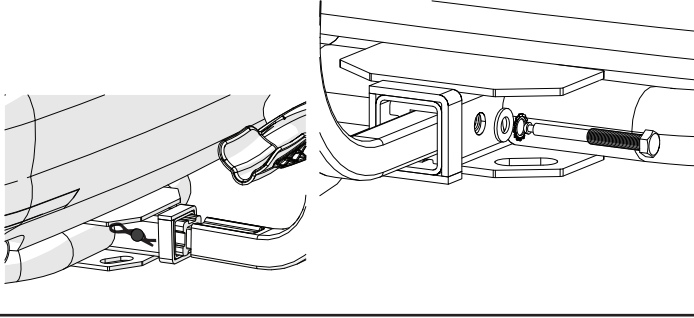

2 Install Pivot Bolt

Align frame (B) with base (A). Install pivot bolt (O) with two M12 flat washers (T) and 1/2" nut (X) using box wrench (AA).

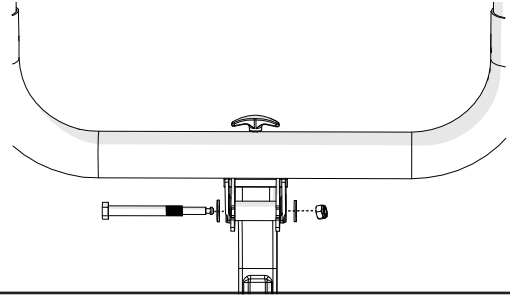

3 Install Inner Wheel Cups

Align inner front wheel cup (C) and inner rear wheel cup (E) with holes in frame (B). Install three M6x85 Allen bolts (P) using M5 hex wrench (DD).

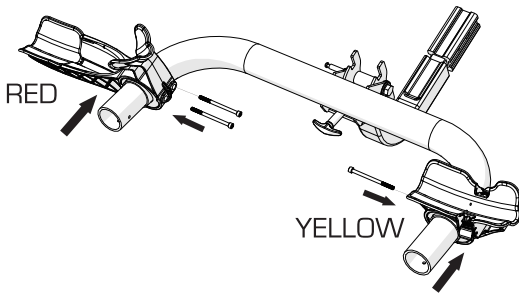

4 Install Right Wheel Cups

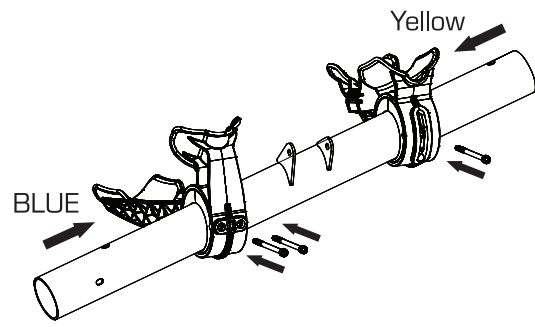

5 Install Left Wheel Cups

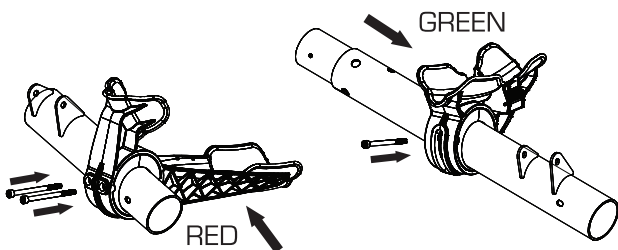

6 Install Frame Arms

Note: Check bolts periodically.

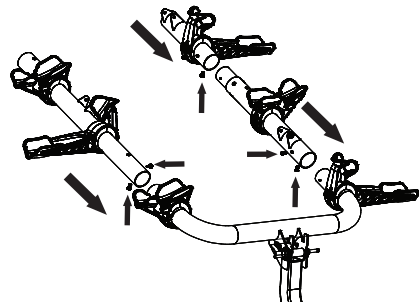

Assembly Instructions

7 Install Rubber Bumpers

Press rubber bumpers (M) into holes into frame arms (G, H, and I).

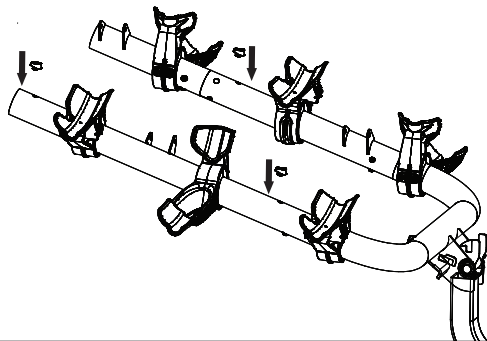

8 Install Ratchet Arms

Align ratchet arms (J) with tabs on frame arms (G, H and, I) with the serrated ratchet features toward the rear of the rack. Install each arm with an M8 x 70 hex bolt (Q), two M8 flat washers (V), and an M8 nut (W), using two box wrenches (AA)

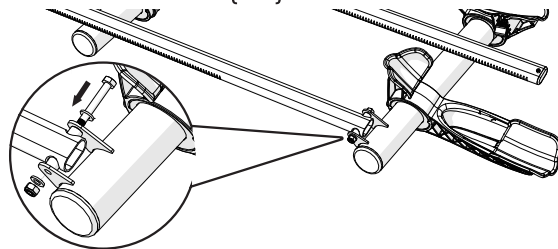

9 Install Wheel Hooks

Slide wheel hooks (K) onto ratchet arms (J) with hook toward the front of the rack.

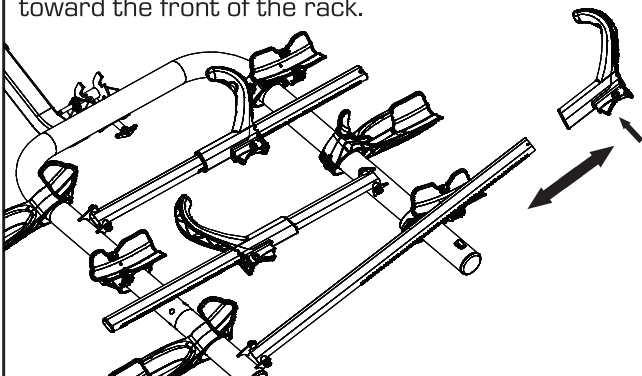

10 Install wheel hook limit Screw

Install M4x6 Allen bolts (R) into ratchet arms (J) using M3 wrench (BB).

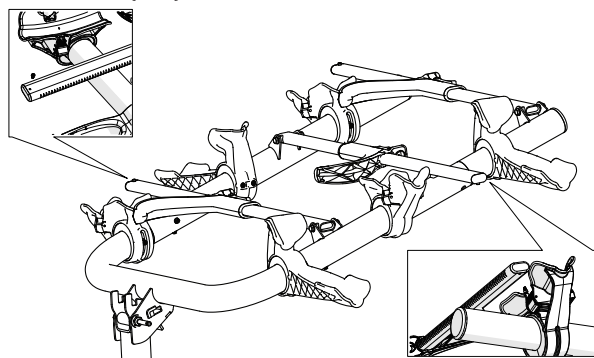

11 Install Rear Wheel Straps

Install rear wheel straps (L) into inner and outer rear wheel cups (E and F).

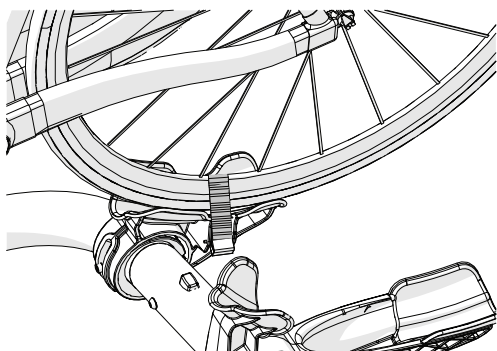

Loading Bikes

1 Open Load Arm

Rotate load arm 180 degrees from stowed position and fully extend hook.

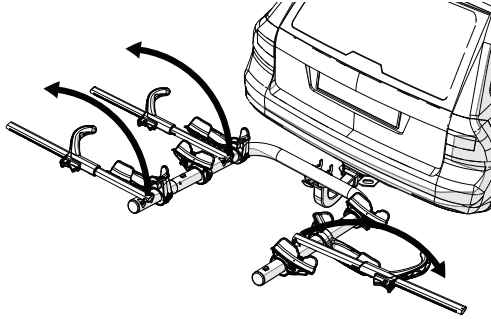

2 Place Bikes on Rack

Load the smaller and/or heavier bike in position nearest to the vehicle. Front wheel should be secure against back stop.

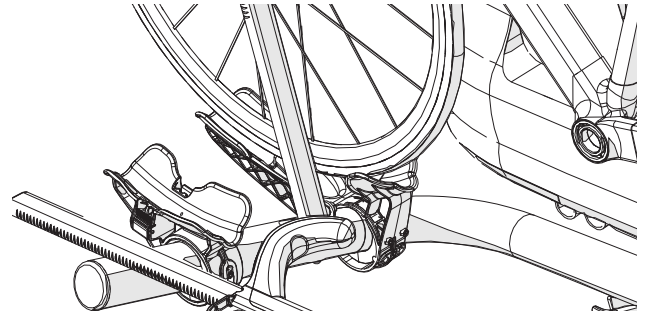

3 Secure Front and Rear Wheels

Rotate load arm over front wheel and tighten hook against fork. Feed wheel strap through rear wheel and into buckle. Pull tight.

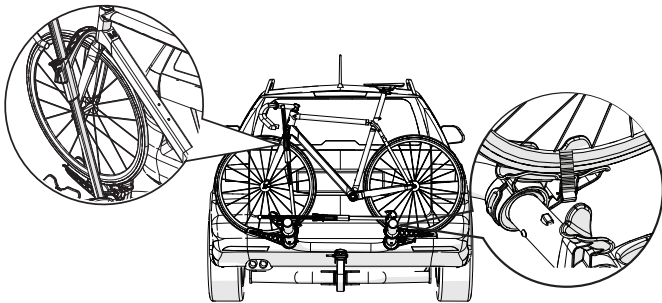

4 WARNING. Check Load Arm Position

Ensure that wheel hook is in contact with fork or brake caliper.

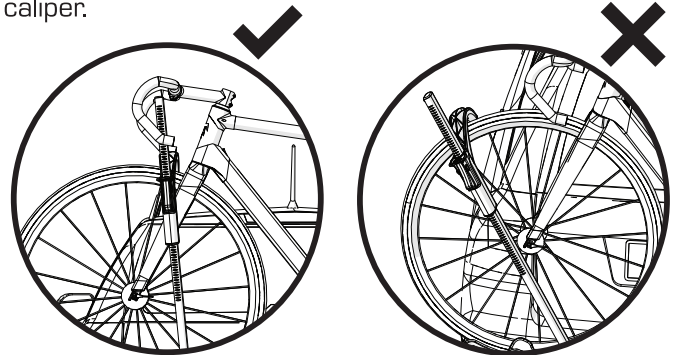

5 Adjust Bike Position

If contact between handlebars and saddle exists, swap bikes so smaller bike is closest to vehicle. This should eliminate any interference between bicycles.

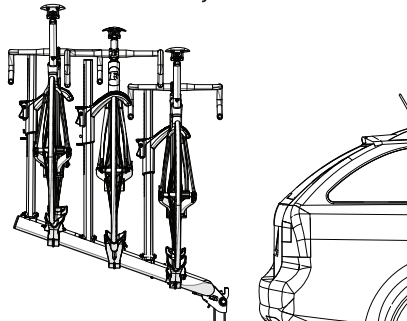

6 Check Mirrors

Be sure loaded bikes do not extend past width of side view mirrors.

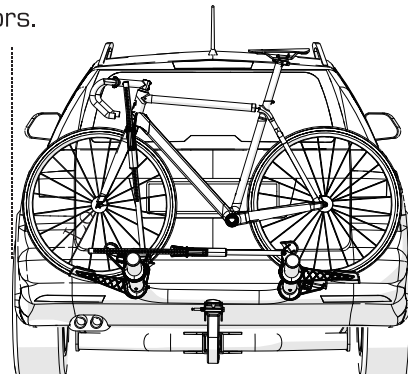

Rack Positions

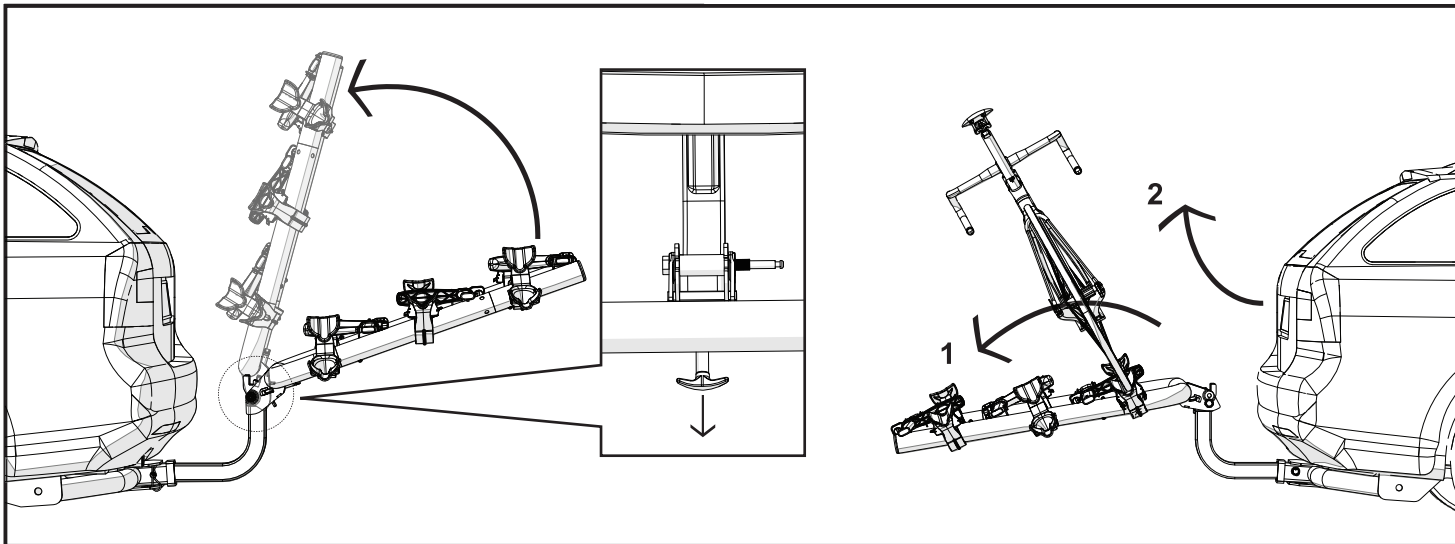

Gently release handle to raise and lower rack into stow, use, and tilt positions. Rack can be folded into stow position when now in use and tilted down for rear vehicle access. Load arms should be stowed flat when rack is not in use. Handle should be fully seated before each use.

Warnings

- If a hitch extension is needed, only anti-wobble hitch extensions by RockyMounts™ can be used with this product
- Remove Baby Seats, Panniers, U-Locks, or Items That Could Detach From The Bicycle
- Do not use bicycle covers, bicycle bras, or equipped with rear disc wheel
- Not intended for off road use. Not intended for use on trailers or towed vehicles
- Not intended for use with trailers, towed vehicles, 1 ton pickups, RV's, or UHV/UTVs
- Bikes and rack can partially block license plate and/or taillights. Please check and adjust accordingly
- Check the car exhaust is not pointing at the rack, bike tires, or rims. Some vehicles may require exhaust diversion to avoid damage
- Do not transport bikes with flat or leaking front tires. Front tire must be inflated for secure transport
- Hitch pin holes need to be a minimum of 1.5" (38mm) from end of hitch receiver
- Locks are only deterrents for thieves, RockyMounts™ Inc. Cannot be held liable for stolen bicycles
- Check All Fasteners Before Each Use
- Remove Bikes and Rack Before Entering Car Wash
- Once a Year, Remove From Car to Clean and Inspect for Damage

Limited Lifetime Warranty

At RockyMounts™ we offer a Limited Lifetime Warranty for products purchased after January 1, 2014 to the original owner. For details of the Warranty, guidelines, and how to make a claim please see rockymounts.com/warranty

Technical Support

Please call us at 303-402-0190 or email at ride@rockymounts.com for questions regarding use, assembly, and support